

Rubber Suspension Blade Scraper Type LC1-5S1

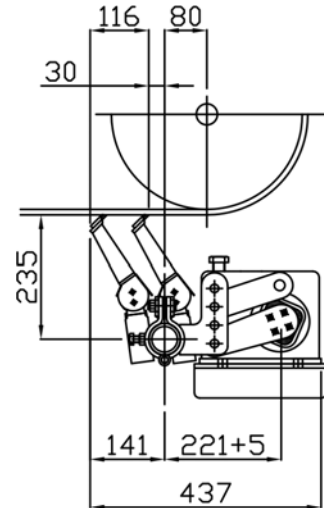
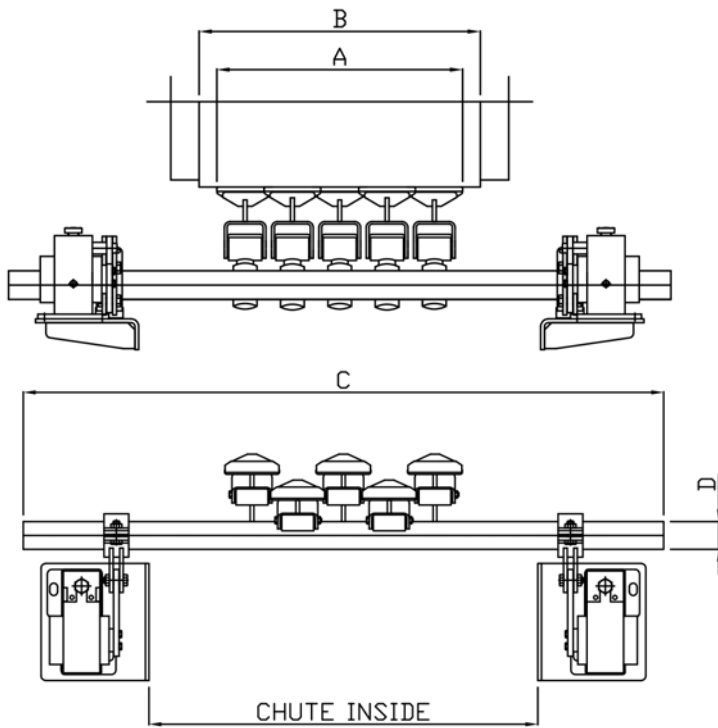

※ Possible to increase pressure is up to 65 mm

Model	Belt size	Tip Size	Module	Body size	D
	A[mm]	B[mm]	Q'ty	C[mm]	
LC1-5S1	600	520	5	1400	∅60.5
	750	620	6	1500	
	800	620	6	1600	
	900	720	7	1700	
	1000	820	8	1800	
	1200	1020	10	2000	
	1400	1220	12	2200	

Without applying pressure above drawing shows the scraper.

During installation, the installation manual is required.

C,P-TYPE BELT CLEANER- Installation Manual

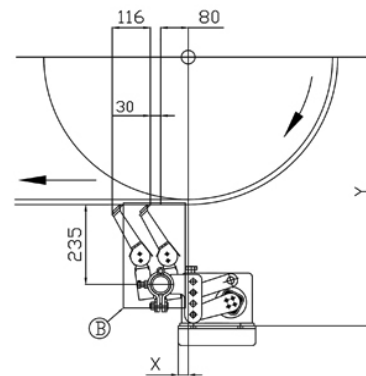
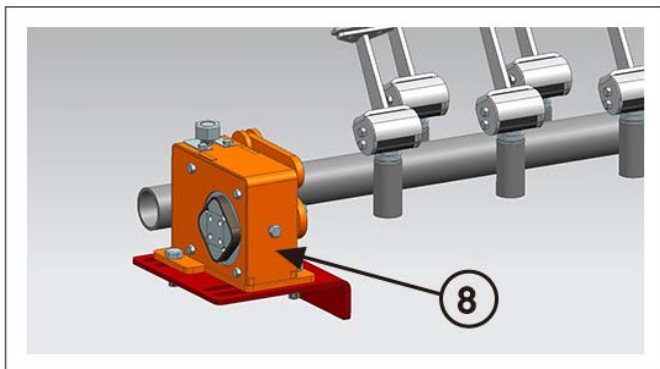
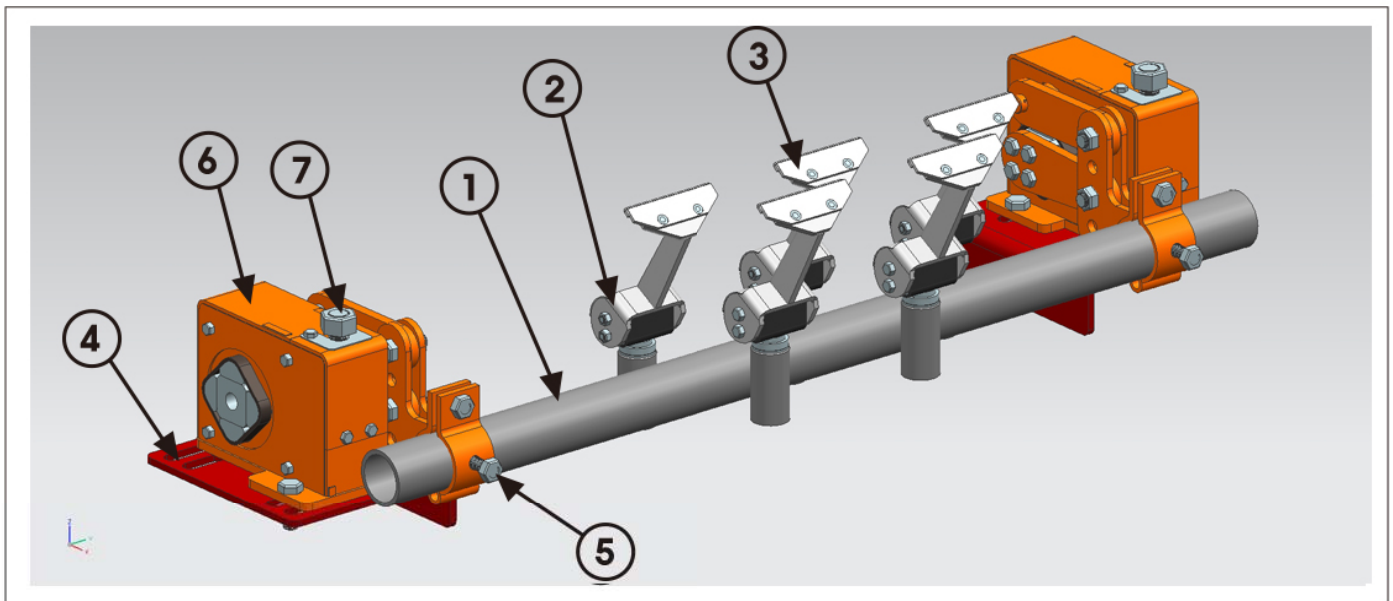

Product Specifications

1. CP Cleaner Body a high-pressure the pipe (STPG) on the molten-plated one that the-standard form referred to as - ①
2. CP Cleaner Holder - ②
3. CP Cleaner carbide tips - ③
4. CP Cleaner installation plate - ④
5. CP Cleaner Body fixed bolt - ⑤
6. CP Cleaner pressurized the device - ⑥
7. CP Cleaner pressure adjustment bolt - ⑦
8. Pressurized After the adjustment fixed bolt - ⑧

This drawing LAUTEC CO. As an asset in a secret LAUTEC CO. Part or all of the public without the prior written consent of, or Must not be reproduced or copied.

INSTALLATION



1. In accordance with the installation drawings Pulley Center 4 (mounting plate) is installed X. Marking Y is the distance.
2. 1 (Cleaner Body) in accordance with the installation drawings Shute enough to fit wall OPEN (B) causes.
3. 4 (installation plate) Marking is welded to the left and right side Shute. Four. 1 (Cleaner Body) and Shute wall where the cut surface and slide the belt three times (tip), and then make a horizontal Five times (fixed bolt) just tighten and fix.
5. "Zeroing" – 7 (pressurized vault) return belt side and three times (Tip) of the front and back will be a match.
6. "Cleaner pressure" pressure on the side arrow to show a marked ↓ return if the grid scale pressure from the 2-3 is completed.
7. Pressure after the completion of eight times (pressure mounting bolts) to fix.
8. Cleaner efficient pressure drops should be pointed in the same way as before.